



For Earth, For Life
Kubota

SVL

KUBOTA COMPACT TRACK LOADER SVL75-2 / SVL95-2s

The outstanding power and exceptional comfort of Kubota's new Compact Track Loaders take high performance and productivity to a new level.



Need more productivity? Put the all-new Kubota Compact Track Loader to work for you.

Kubota, a trusted and world-leading manufacturer of construction equipment, is proud to introduce the all-new SVL75-2/SVL95-2s Compact Track Loaders. These new compact track loaders deliver best-in-class bucket breakout force and lifting capacity, outstanding stability, a wide and comfortable operator area, and much more. When it comes to high performance, reliability and comfort, the road leads to Kubota.

- **OUTSTANDING PERFORMANCE**
- **EXCEPTIONAL COMFORT**
- **EASY MAINTENANCE AND IMPRESSIVE DURABILITY**

SVL75-2

Engine gross horsepower : 74.3 HP (55.4 kW)

Rated operating capacity (35% of tipping load) : 2300 lbs (1043 kg)

Bucket breakout force : 6204 lbs (2814 kg)

Operating weight (Including operator weight 165 lbs) : 9039 lbs (4100 kg)



COMPACT TRACK LOADER SVL75-2/SVL95-2s



SVL95-2s

Engine gross horsepower : 96.4 HP (71.9 kW)

Rated operating capacity (35% of tipping load) : 3200 lbs (1451 kg)

Bucket breakout force : 7961 lbs (3611 kg)

Operating weight (Including operator weight 165 lbs) : 11299 lbs (5125 kg)



OUTSTANDING PERFORMANCE

Kubota engine

Common Rail System and Diesel Particulate Filter (DPF) Muffler

The Common Rail System (CRS) electronically controls the timing and amount of fuel that is injected in stages, ensuring optimal combustion for greater gas efficiency, better fuel economy and less engine noise. The SVL Series is Tier IV-certified, thanks to the emissions-reducing combination of Exhaust Gas Recirculation (EGR) and the Diesel Particulate Filter (DPF) Muffler.

● Powerful Kubota engine

The powerful and reliable Kubota-built engine gets the job done quickly and easily with 74.3 hp (SVL75-2) or 96.4 hp (SVL95-2s).

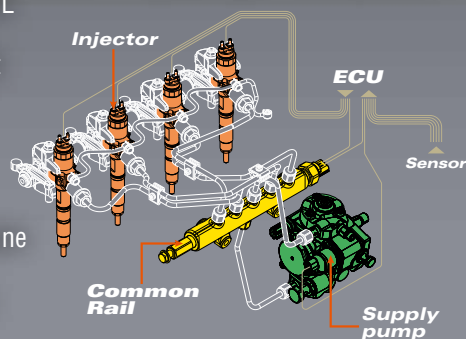

● SCR meter panel

An SCR system helps the SVL95-2s meet Final Tier4 requirements. A quick glance at the digital panel tells you how much Diesel Exhaust Fluid (DEF) remains in the tank and also when to refill it.





	SVL75-2	SVL95-2s
Bucket Breakout Force:	6204 lbs	7961 lbs
Arm Breakout Force:	4766 lbs	6742 lbs
Tipping Load:	6570 lbs	9143 lbs

● **Automatic regeneration system**

Kubota's original automatic regeneration system automatically burns accumulated particulate matter (soot) in the DPF muffler to keep the muffler clean for longer operation. For operational and safety reasons, automatic regeneration can be turned off with the inhibit switch when compact track loader is operating in areas that are near people, animals, and flammable materials.



● **Electronic Travel Torque Management**

Electronic Travel Torque Management System lets you work faster with more power. The ECU constantly monitors the load of the machine to optimally control hydraulic pump output according to the load, preventing engine stalls for smoother operation even under severe conditions.

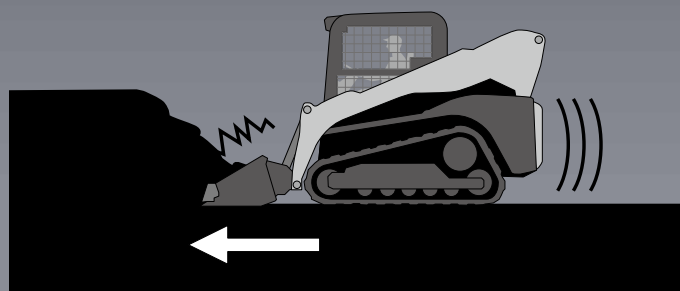

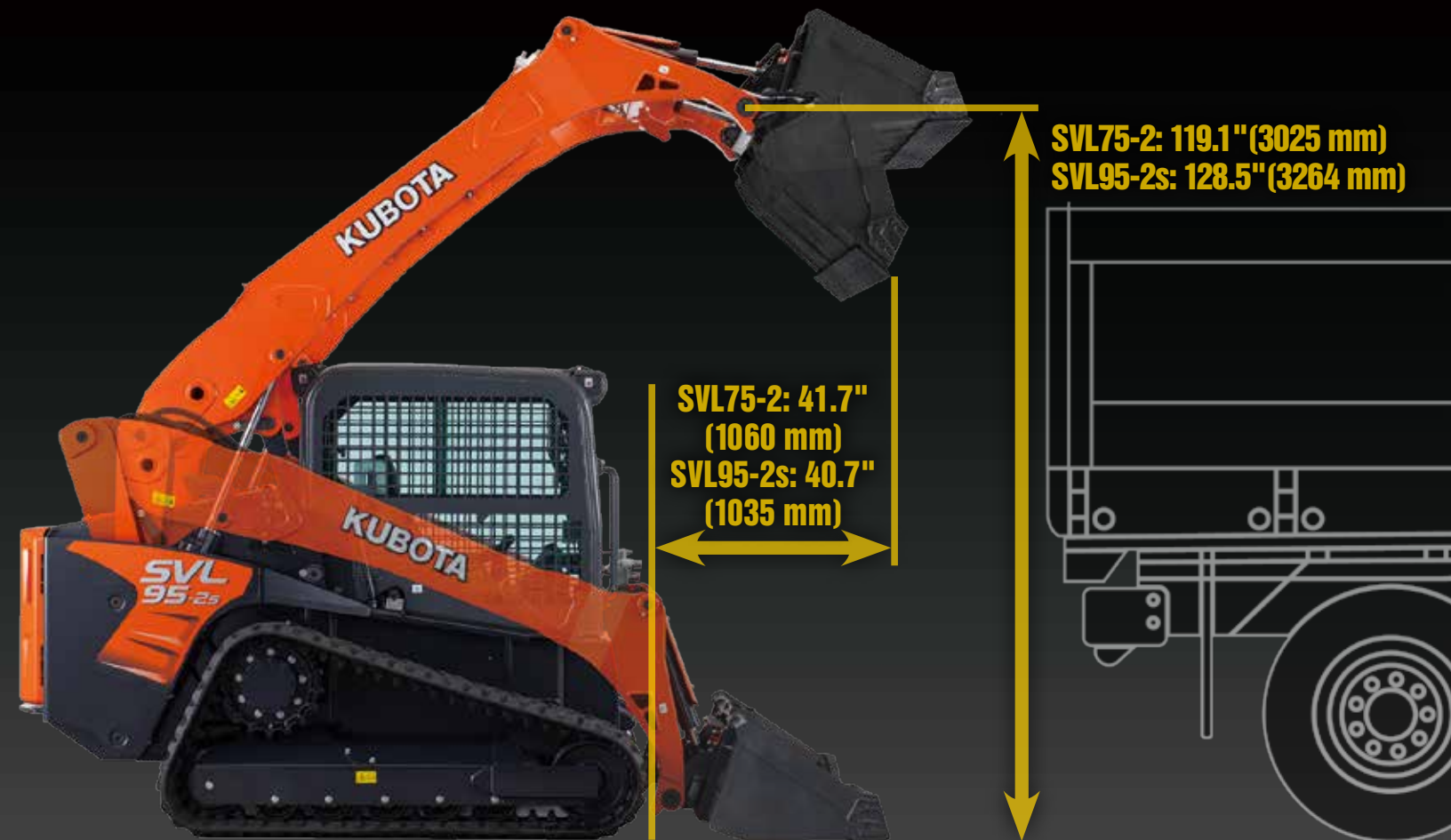

Kubota Unique Vertical Lift Design



- Long Reach for Maximum Lifting and Dumping
- High Bucket Hinge Pin Height

Kubota's unique vertical lift is designed to deliver an exceptionally long reach of 41.7 inches (SVL75-2) and 40.7 inches (SVL95-2s). In addition, the tip of the arm is optimally shaped for a tall hinge pin height of 119.1 inches (SVL75-2) / 128.5 inches (SVL95-2s) for easy dumping into trucks.



- Standard Self-leveling Function

This feature helps keep the bucket or fork in a horizontal position without the need to manually adjust the angle during lifting.

Travel Performance

1. Standard Two-speed Travel

Shift from low gear at 4.7 mph (SVL75-2) / 5.0 mph (SVL95-2s) to high gear at 7.1 mph (SVL75-2) / 7.3 mph (SVL95-2s) to get the job done faster.

2. Pilot Valve with Shuttle Piston

This ensures consistent oil flow which improves stability when going straight.

3. Higher Ground Clearance

A high ground clearance of 11.7 inches (SVL75-2) / 11.5 inches (SVL95-2s) lets you travel over large obstacles with ease.

4. Strong Traction Force

Kubota's original track lug design gives you more grip and a stronger traction force of 9678 lbs (SVL75-2) / 12178 lbs (SVL95-2s).



Powerful hydraulic system

● Load Sensing System (SVL95-2s)

● Enhanced Control Valve System (SVL95-2s)

The SVL95-2s features a new Load Sensing System and improved control valve to provide even more powerful pushing and driving forces, even for combined attachment operations. Plenty of power to travel on slopes and handle attachment work also means you'll get the job done faster.

● Adjustable Maximum Oil Flow Control (Option) (SVL95-2s)

Quick and easy 5 modes of the AUX flow ensures the optimal flow rate for every job you do. Adjustable Maximum Oil Flow Control is available only for high flow.

● Enhanced High-flow Hydraulics (Option) (SVL95-2s)

This option can increase the hydraulic capacity for attachments requiring larger hydraulics. Both 1/2" and 3/4" couplers are included.

Aux. hydraulic flow	Std.	23.1 gpm (87.6 lpm)
	High	40 gpm (152 lpm)



EXCEPTIONAL COMFORT

Comfortable Cab

● Wider Cab Entrance

A wider entrance makes it easier to get in and out.

● Wide And Clean Cab

The spacious interior minimizes fatigue even during long work hours.

● High-back Full Suspension Seat

The standard suspension seat offers outstanding comfort. (Air Suspension seat is optional)

● Arm Rest

The spacious cab also includes ergonomically placed arm rests on the right and left sides of the seat to minimize operator fatigue. The arm rests have been designed to increase operator space.

● Wide Leg Room

The cab provides ample leg room to reduce operator fatigue.

● Ready for radio installation (Option)

The SVL-series Factory Closed cab now comes prewired with speakers already installed, all that needs to be added is the radio.

● Easy-clean Floor Mat and Drain Outlet

The soft rubber floor mat is easy to remove and clean. And with the built-in drain outlet, the mat can be washed in the cab.



Excellent 360° Visibility

The edge of the bucket can be seen from the seat. Improved visibility translates to better safety on the job.



● Hand/Dial and Foot Throttle

The SVL95-2s' dial and foot throttle, and the SVL75-2's hand and foot throttle both allow you to match the engine speed to the task. The hand/dial throttle is ideal for jobs requiring constant engine speed such as cold planing, trenching or snow blowing. The foot throttle lets the operator vary engine speed for other applications.



(SVL75-2)



(SVL95-2s)



(SVL75-2/SVL95-2s)

EXCEPTIONAL COMFORT

Pressurized Cab

The cab is pressurized to keep dust, flying debris, and insects away to enhance comfort on the job. Furthermore, noise is kept down to let you work for long hours with minimal fatigue.



Excellent Air Conditioning Performance

● Optimized Air Conditioning

Thanks to improved vents, the climate control system provides an optimized airflow for outstanding cooling and heating performance—and supreme operator comfort—all year round.

● Enhanced Defrosting and Demisting Functions

Ample airflow prevents the windows from fogging up or freezing during the cold months of the year.



CAB

Easy-open Sliding Windows

The sliding front door can be opened regardless of the position of bucket or attachment; allowing you to get in or out in difficult situations and also work with the front door open. It is a added benefit when hooking up attachments, improving the visibility and safety.

The sliding side windows are split in the middle and can be opened separately from the front or rear.



EASY MAINTENANCE IMPRESSIVE DURABILITY

Easy Maintenance

- **Routine Checks**

Simply open the rear bonnet to access all components for daily routine inspections.

- **Slide-and-tilt Radiator and Oil Cooler**

The radiator can be tilted for easy cleaning.

- **DEF easy refill access (SVL95-2s)**



- **Tilt-up Cab**

The cab can be tilted 72° without having to lift the arm, allowing easy access to the hydraulic pumps, valves, lines and hydraulic tank.



- **Large Space for Tool Box**

The SVL75-2 offers a convenient and large tool box for storing a grease gun and other necessities.



ANCE & DURABILITY

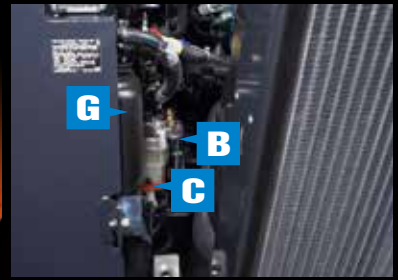

- A. Dual Element Air Cleaner**
- B. Fuel Filter**
- C. Water Separator**
- D. Maintenance-Free Battery**
- E. Coolant**
- F. Slide-and-tilt Radiator**
- G. DEF tank**

Diesel Particulate Filter (DPF) and Selective Catalytic Reduction (SCR)

The Diesel Particulate Filter and Selective Catalytic Reduction meet the latest Tier4 diesel emissions regulation by collecting particulate matter (PM) and NOx from exhaust gas for cleaner exhaust emissions.



Impressive Durability

1. Welded, Integrated Mainframe and Undercarriage

The undercarriage forms an integral part of the main frame for maximum durability.

2. Kubota Original Rubber Tracks

Kubota's original rubber tracks offer outstanding durability and long-life performance. Furthermore, Kubota's original lug pattern prevents soil from accumulating and improves traction force. 15" (380 mm) wide tracks are optional for the SVL75-2.

3. Triple Flange Lower Track Rollers

A highly reliable triple flange design not only minimizes the risk of detracking, but improves stability as well. They are lifetime sealed and lubricated.



1

2

3

VERSATILITY

With a wide variety of attachments available*, Kubota Compact Track Loaders are the most versatile machine on your jobsite.

**Not all attachments are OEM-KUBOTA.*

Auger



Grapple Bucket



Quick Coupler

An optional Hydraulic quick coupler is available. You can attach or remove attachments using a switch without leaving the seat.



Pallet Fork



Sweeper



Breaker

Cold Planer

4-in-1 Bucket

Snow Blade

Brush Cutter

Broom

Tiller

Snow Blower

Buckets

Dozer Blade

Tilt Attach

EQUIPMENT

STANDARD EQUIPMENT

- Open CAB (ROPS / FOPS Level 1)
- Top / Rear window
- Suspension seat
- 2" Retractable seat belt
- Operator presence control
- Pull down arm rest
- Hand/Dial and Foot throttle
- 12V electric outlet
- Horn
- Lockable fuel cap
- Backup alarm
- Working lights (Front 2 / Rear 2)
- Glow plug
- Mechanical quick coupler
- Loader arm float function
- Bucket self-leveling (up only)
- Wet disc parking brakes
- Two-speed travel
- Rubber crawler SVL75-2-12.6" (320mm)
- Rubber crawler SVL95-2s-17.7" (450mm)

OPTIONAL EQUIPMENT

- High-flow hydraulics (1/2" and 3/4" couplers for SVL95-2s)*
- Adjustable maximum oil flow*
- 14-pin coupler for attachments
- Wide rubber crawler* SVL75-2-15" (380mm)
- Radio Ready*
- Air ride suspension seat
- 3" Retractable seat belt
- Rear bonnet lock Kit
- Rear view mirror
- Hydraulic quick coupler*
- Strobe light
- Beacon light
- Engine block heater
- Radiator screen
- ...and much more.

*Factory Option

SPECIFICATIONS

Model		SVL75-2		SVL95-2s			
Type of operator station		Open CAB / Closed CAB		Open CAB / Closed CAB			
Engine	Model	V3307-CR-TE4		V3800-TIEF4			
	Output (SAE J1995 gross)	HP (kW)/rpm	74.3 (55.4)/2400		96.4 (71.9)/2400		
	Output (SAE J1995 net)	HP (kW)/rpm	73.2 (54.6)/2400		95.0 (70.8)/2400		
	Displacement	cu.in. (cc)	203.3 (3331)		230.0 (3769)		
	Cylinders		4		4		
	Bore × Stroke	in.(mm)	3.7 (94) × 4.72 (120)		3.94 (100) × 4.72 (120)		
Aspiration		Turbocharged		Turbocharged			
Loader Performance	Rated operating capacity-35% tipping load		lbs. (kg)	2300 (1043)		3200 (1451)	
	Tipping load		lbs. (kg)	6570 (2980)		9143 (4147)	
	Breakout force	Bucket	lbf. (kg)	6204 (2814)		7961 (3611)	
		Lift arm	lbf. (kg)	4766 (2162)		6742 (3058)	
	Lift arm path			Vertical		Vertical	
Undercarriage	Track Width	Standard	in. (mm)	12.6 (320)		17.7 (450)	
		Wide	in. (mm)	15.0 (380)		N/A	
	Ground pressure	Standard	psi	5.6 / 5.8		4.4 / 4.5	
		Wide	psi	4.7 / 4.9		N/A	
	Track rollers (per side)			4		5	
	Track ground contact length		in. (mm)	56.5 (1436)		65.6 (1667)	
	Travel speed	Low	mph (km/h)	4.7 (7.5)		5.0 (8.0)	
		High	mph (km/h)	7.1 (11.5)		7.3 (11.7)	
Traction force		lbs. (kg)	9678 (4390)		12178 (5524)		
Min. ground clearance		in. (mm)	11.7 (296)		11.5 (293)		
Hydraulic system	Aux. hydraulic flow	Std./High	gpm (ℓ/min.)	17.4 (66.0) / N/A		23.1 (87.6) / 40.0 (152)	
	Aux. hydraulic pressure		psi (kgf/cm ²)	3185 (224.0)		3553 (249.8)	
Service refill capacities	Hydraulic system		gal. (ℓ)	15.9 (60)		17.96 (68)	
	Hydraulic tank		gal. (ℓ)	9.2 (35)		10.1 (38.1)	
	Fuel tank		gal. (ℓ)	24.6 (93)		28.8 (109)	
	DEF tank		gal. (ℓ)	N/A		5.0 (18.8)	
Operating weight (Includes operator weight 165lbs.)		lbs. (kg)	9039 (4100) / 9315 (4225)		11299 (5125) / 11574 (5250)		

The company reserves the right to change the above specifications without notice. This brochure is for descriptive purposes only. Please contact your local Kubota dealer for warranty information. For your safety, Kubota strongly recommends the use of a Rollover Protective Structure (ROPS) and seat belt in almost all applications.

DIMENSIONS

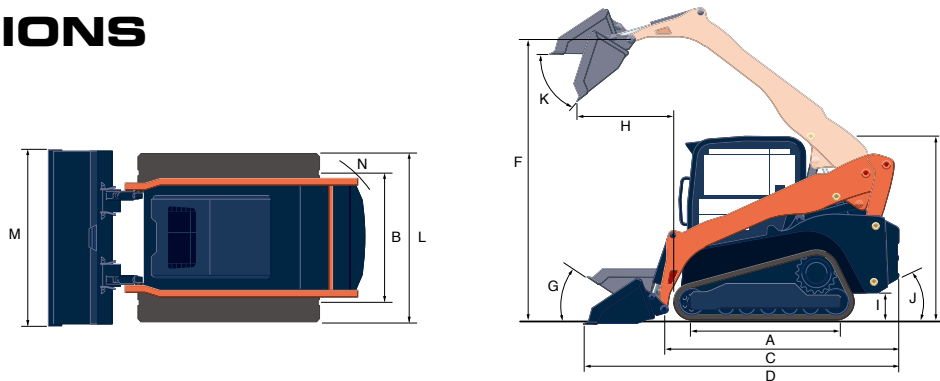

Model		SVL75-2		SVL95-2s			
A	Length of track on ground	in. (mm)	56.5 (1436)		65.6 (1667)		
B	Track gauge	in. (mm)	53.3 (1355)		59.5 (1512)		
C	Length w/o bucket	in. (mm)	109 (2768)		123.5 (3137)		
D	Length w/bucket on ground	in. (mm)	140.8 (3576)		154.6 (3929)		
E	Height to top of cab	in. (mm)	82 (2083)		83.3 (2116)		
F	Bucket hinge pin height at max. lift	in. (mm)	119.1 (3025)		128.5 (3264)		
G	Rollback angle at carry position	degree	27		27		
H	Reach at max. lift and dump	in. (mm)	41.7 (1060)		40.7 (1035)		
I	Ground clearance	in. (mm)	11.7 (296)		11.5 (293)		
J	Departure angle	degree	31.5		31		
K	Max. dump angle	degree	40		43		
L	Vehicle width	Standard track / Wide track	in. (mm)	65.9 (1675) / 68.3 (1735)		77.2 (1962)	
M	Width with bucket		in. (mm)	68 (1727)		80 (2032)	
N	Turning radius from center-machine rear		in. (mm)	107.1 (2720)		127 (3220)	



KX080-4

From our excavators, skid steers and wheel loaders to our tractor/loader/backhoes, Kubota offers a wide range of reliable, high-performance construction equipment to get the job done right.



M62



SSV65/SSV75

©2015 Kubota Corporation



KUBOTA TRACTOR CORPORATION

Kubota Tractor Corporation, 3401 Del Amo Boulevard, Torrance CA 90503
 Western Division: 1175 S. Guild Ave., Lodi, CA 95240 Tel (209) 334-9910
 Central Division: 14855 FAA Boulevard, Fort Worth, TX 76155 Tel (817) 571-0900
 Northern Division: 6300 at One Kubota Way, Groveport, OH 43125 Tel (614) 835-1100
 Southeast Division: 1025 Northbrook Parkway, Suwanee, GA 30024 Tel (770) 995-8855

Visit our web site at: www.kubota.com

