

R

R420S

Kubota

SPECIFICATIONS

Specifications

| | MODEL | ROPS / FOPS | 2-Post Canopy | R420S | Cab |
|------------------------------|-------------------------------------|-----------------------------|----------------------------------|---|--------|
| ENGINE | MAKE & MODEL | | Kubota D1503-M-T-E3 | | |
| | TYPE | | Liquid cooled, 3-Cylinder Diesel | | |
| | HORSEPOWER | (SAE J1995 gross) | 39.2 @ 2,600 rpm | | |
| | | (SAE J1349 net) | 37.1 @ 2,600 rpm | | |
| | DISPLACEMENT | | 91.4 cu. in. | | |
| | TURBOCHARGER | | YES | | |
| E-TVCS | | YES | | | |
| DIMENSIONAL SPECIFICATIONS | OVERALL HEIGHT | A | 98.8" | | 103.5" |
| | OVERALL LENGTH (w/ Bucket & Weight) | B | | 165.8" | |
| | OVERALL WIDTH (w/ out Bucket) | C | | 59.8" | |
| | OVERALL OPERATING HEIGHT | D | | 137.8" | |
| | HEIGHT TO HINGE PIN | E | | 9'2.7" | |
| | DUMP ANGLE FULLY RAISED | F | | 45° | |
| | DUMP HEIGHT | G | | 7'4.4" | |
| | REACH FULLY RAISED | H | | 30.8" | |
| | DIGGING DEPTH | I | | 2.6" | |
| | WHEELBASE | J | | 69.9" | |
| | GROUND CLEARANCE | K | | 11.3" | |
| | TREAD | L | | 46.5" | |
| | ANGLE OF ARTICULATION (Each Way) | M | | 40° | |
| | FRAME OSCILLATION (Each Way) | N | | 8° | |
| LIFTING SPECIFICATIONS | TIPPING LOAD STRAIGHT (SAE Rating) | | | | |
| | with Bucket | | | 4,585 lbs. | |
| | with Pallet Forks | | | 3,300 lbs. | |
| | TIPPING LOAD FULL TURN (SAE Rating) | | | | |
| | with Bucket | | | 3,830 lbs. | |
| | with Pallet Forks | | | 2,800 lbs. | |
| OPERATING LOAD | | | | | |
| | with Bucket | | | 1,925 lbs. | |
| | with Pallet Forks | | | 1,400 lbs. | |
| COUNTER WEIGHT / Standard | | | 1,100 lbs. | | |
| OPERATIONAL SPECIFICATIONS | STANDARD BUCKET CAPACITY | | | .50 cubic yards | |
| | BUCKET BREAKOUT FORCE | | | 6,550 lbs. | |
| | LOADER RAISE TIME | | | 4.4 seconds | |
| | LOADER LOWER TIME | | | 3.0 seconds | |
| | BUCKET DUMP TIME | | | 1.1 seconds | |
| | DRAW BAR PULL | | | 5,280 lbs. | |
| | LOADER CLEARANCE CIRCLE | O | | 23'10.6" | |
| | OPERATING WEIGHT | | | 7,450 lbs. | |
| DRIVE TRAIN & HYDRAULIC PUMP | STANDARD TIRES | | | 12.5/70-16 8-ply | |
| | TRANSMISSION | | | Load Sensing Transmission | |
| | NUMBER OF SPEEDS | | | 1 Forward/ 1 Reverse | |
| | TRAVEL SPEED | | | 0 to 12.5 mph | |
| | | w / Travel Speed Limiter On | | 0 to 3.1 mph | |
| | BRAKES | / Service | | Enclosed, Self Adjusting Wet Disc | |
| | | / Parking | | Spring Applied, Hydraulic Released Wet Disc | |
| | PUMP TYPE AND OUTPUT | | | | |
| | | / LST | | 17.8 gpm @ 5,800 psi | |
| | | / MAIN | | 10.3 gpm @ 3,550 psi | |
| | / CHARGE | | 4.1 gpm @ 495 psi | | |
| AUXILIARY HYDRAULIC FLOW | | | 11.1 gpm front and rear | | |
| FLUID REFILL | FUEL TANK | | 14.3 gal. | | |
| | HYDRAULIC SYSTEM | | 15.9 gal. | | |
| | HYDRAULIC RESERVOIR | | 11.1 gal. | | |

Specifications subject to change without notice. For your safety, ROPS with a seatbelt is strongly recommended by Kubota in almost all applications.

R

R420S

Kubota

SPECIFICATIONS

DIMENSIONS

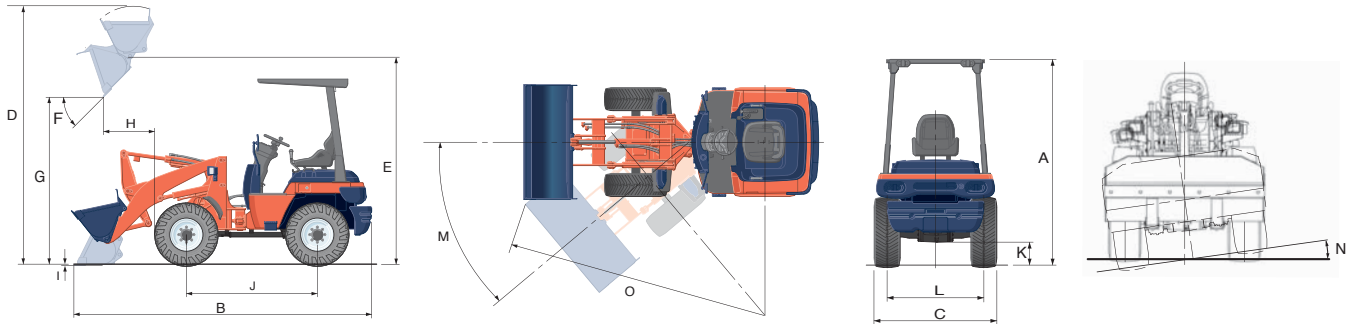

BACKHOE SPECIFICATIONS

| MODEL | | R420S/RBK4009S |
|--------------------------------------|---|----------------|
| Reach from centerline of swing pivot | A | 145.7" |
| Overall operating height | B | 126.8" |
| Loading height | C | 80.3" |
| Digging depth (2' flat bottom) | D | 107.3" |
| Digging depth (Maximum) | E | 108.3" |
| Side shift (Each way) | - | 19.5" |
| Digging force bucket | - | 4,100 lbs. |
| Digging force dipperstick cylinder | - | 2,755 lbs. |

