



Articulation and Frame Oscillation

Our wheel loaders are most often operated in heavy terrain and we include the features for top performance. Articulation allows the rear tires to follow the same track path as the front tires for greater maneuverability and control of the loader. Rear frame oscillation is intentionally chosen over rear axle oscillation for superior workability in uneven ground conditions.



Hybrid Link System

The well balanced cylinder position of the Kubota Z link system combines the advantages of both Z link and parallel link systems. You get strong bucket force when excavating and grading, and a lift path almost parallel to the ground for superior reach and lifting.



Multi-function Control Lever

You'll get more work done in less time with the R630's multifunction operating lever. All major loader functions—Speed Up/Down, Forward / Reverse, Neutral, Differential Lock, and Auxiliary Hydraulics — are on a single lever that is easy to operate with just one hand. The 5-step Speed Up/Down buttons let you quickly change speeds and work at the optimum speed for the task at hand.



Adjustable Wrist Rest

More than just a place to put your arm, the right-side wrist rest is an important factor in comfort during wheel loader operations. It reduces fatigue by reducing arm movement and allowing you to more easily operate the hand lever.



Multi-Speed Control

The R630 travel speed can be set in five stages. Quickly change speeds and work at the optimum speed for the attachment mounted and task at hand. You can jump to the lowest or the highest travel speed when the speed change button is held for a few seconds.



E-HST 4 Mode Transmission

The Kubota electronic HST offers you 4 different operating modes. The operator can quickly and easily choose the most suitable mode depending on the machine's application. Normal mode is the default and the machine starts that way. Experience plenty of power and speed for most all job functions.

Attachment mode allows operators to independently control travel speed and auxiliary hydraulic flow. Attachment mode is ideal for brooms, sweepers, or other hydraulic motor function attachments for the front loader.

Select Eco mode to reduce fuel consumption, up to 15%, by limiting the engine rpm. This mode is exchanging high traction force for handling material in the yard or load and carry functions for fuel savings.

Select Power mode when you need strong traction force. This mode reduces travel speed so that the machine can provide up to an additional 40% traction force, ideal for excavating.





Differential Lock

100% On-Demand, Front and Rear
Kubota's 4-wheel drive lets you outmuscle challenging terrain, such as mud, sand, and snow. When loose or soft terrain causes the wheels to lose grip, depress the conveniently located differential lock switch to restore traction.

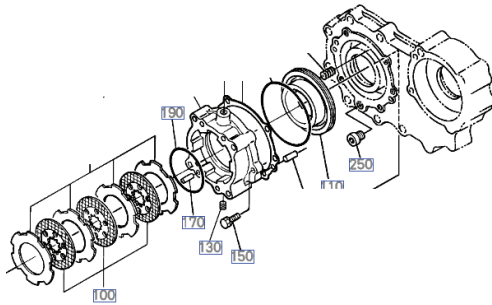

Wet Disk Brakes

The wet disk brake system prevents mud and water contamination and ensures stable brake performance and long reliability. The adoption of independent friction plates on the service brakes and the parking brakes provides reliability and durability in tough operating conditions.



Parking Brake

The electrically activated mechanical parking brake can be applied or released simply by pressing the switch. It prevents the machine from moving until you give the command.



Inching and Brake Pedal

The R630 achieves the best feeling of inching operation in this class. The smooth, fine inching control and fast acceleration contributes to excellent efficiency when using the V-shift turn for truck loading operations. A right side inching pedal is available as an option.



Auxiliary Ports

Conveniently located on the rear of the attachment quick coupler, flat face, no drip couplers provide easy access to power your hydraulic attachments. Auxiliary ports are plumbed separately from hydraulic quick coupler plumbing.



Hydraulic Quick Coupler

Quickly and conveniently exchange attachments to satisfy the needs of most any job. Choose between hydraulic skid steer style or hook and pin style (shown) couplers to speed you on your way. Control plumbing is standard on all models.



Quick Coupler Attachment Unlock Switch

Save time and money exchanging attachments without leaving the seat. The attachment unlock switch safely speeds your way through attachment exchanges with the flick of a switch and the push of a lever.



Cab with Air Conditioning

Your job is tough enough—your cab environment shouldn't be. We focused our efforts on creating a cab that maintains your peak performance all day long. The result? A factory cab that offers a clear field of view, a fully adjustable suspension seat, air conditioning and heat, low sound, minimal vibration, and more.



ISO Mounted Canopy / Cab

Comfortable operators are so much more productive at the end of the day. R630 operator exposure to noise and vibration is reduced by isolating the cab from the machine frame using isolation mounts.



Strong Air Circulation

The overall air circulation in the cab has been improved, thanks to a stronger cooling/heating unit and the positioning of vents all around the operator to offer better all-round comfort.



Full Featured Suspension Seat

A full size suspension seat enhances operator comfort. The padded seat features fore and aft positioning, weight compensation, height adjustment, adjustable head rest, tilt back, and a left side arm rest for optimum comfort.



Modern Digital Display

Bright and easy-to-read, the digital instrument panel tells you at a glance everything you need to know about the machine's functions and conditions.

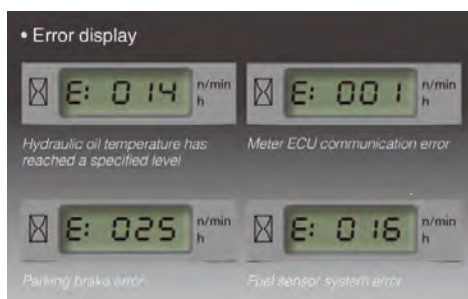

Digital Diagnostic Indicators

A full set of diagnostic indicators automatically monitor critical machine conditions, letting you concentrate on the job at hand.



Tilt Steering

With the flick of a lever, the steering wheel can be tilted up or down to the most comfortable and efficient position for drivers of all sizes.



Rounded Glass

Rounded glass on the top and corners, plus a sloped engine cover, reduce noise levels and provide good visibility for operators in all directions.



R Series

Features

R630



ROPS / FOPS Certified Canopy / Cab

Forged and attached at the Kubota factory, both the Roll-Over Protective Structure (ROPS) and Falling Object Protective Structure (FOPS) meet the applicable ISO, SAE and OSHA standards



Transportation Tie Downs

With an overall height below 98", the R630 slips easily under road bridges when transporting between job sites. Six tie-down points and an articulation lock allow simple attachment to a trailer for secure transportation.



Mirrors and Lighting

Mirrors come standard on canopy and cab models. Boom mounted front lights, turn signals, emergency flashers, and tail lights are standard equipment for all models. Cab models include cab mounted work lights. Canopy mounted work lights are optional as are rear working lights. All are indicators of Kubota's emphasis on operator visibility on the job site.



Kubota Original Tier 4 Final Engine

The R630 is powered by a robust 61.2 HP diesel engine. Built by Kubota, this reliable engine features low noise, low vibration, and low fuel consumption. Many of our competitors do not build their own wheel loaders nor use their own engines.

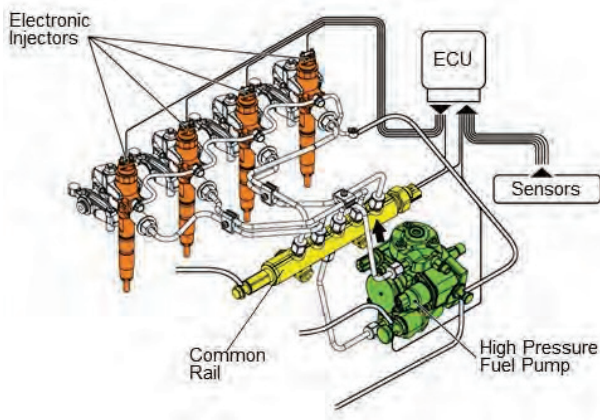

Common Rail Fuel System

The Common Rail System electronically controls the fuel injection timing and amount in stages rather than all at once for optimal combustion. The results are great efficiency, better fuel economy and less engine noise. Its combination with the Exhaust Gas Recirculation (EGR) and Diesel Particulate Filter (DPF) Muffler reduces emissions to make the R630 Tier IV Final compliant.



Automatic Regeneration

Kubota's original automatic regeneration system automatically burns accumulated particulate matter (soot) in the DPF muffler to keep it clean. For operational reasons regeneration can be turned off and manually accomplished at a more appropriate time.



Easy to Service

Servicing the Kubota R630 is a snap, helping to reduce downtime and letting you get back to work as quickly as possible. The engine bonnet at the rear opens wide, providing quick and easy access to the machine's main service areas.



Right Side Access Panel

Conveniently located behind a locking panel, the right side access panel provides ground level access to electrical components for inspection.



Fuel Fill Port, Refueling Assistant

The R630 locking cap is conveniently located at hip level and easy to access, even when trailer mounted. When refueling, simply press the refueling signal button located next to the fuel fill port. To monitor the progress. The beeping signal accelerates as the fuel approaches full and thus avoid spillage.



Left Side Access Panel

Quick open panels provide easy access to daily inspections items like the maintenance free battery and a storage area.